

FF3707



Detachable carriage with twist lock and universal head

One side of the carriage can be removed to attach or detach the carriage to/from the IFF Rail 80 or IPE80 beam.
 Universal head with 1-1/8" and 5/8" female and 5/8" male attachment



material main body: steel & aluminium
 part: blue plastic



finish: grey powder coating with orange peel finish RAL 7016



weight: 1,868 kg
 4,117 lb



volume: 0,0060 cu m
 0,2120 cu ft



max. load: 100 kg
 220 lb



weight: 1,970 kg
 4,339 lb

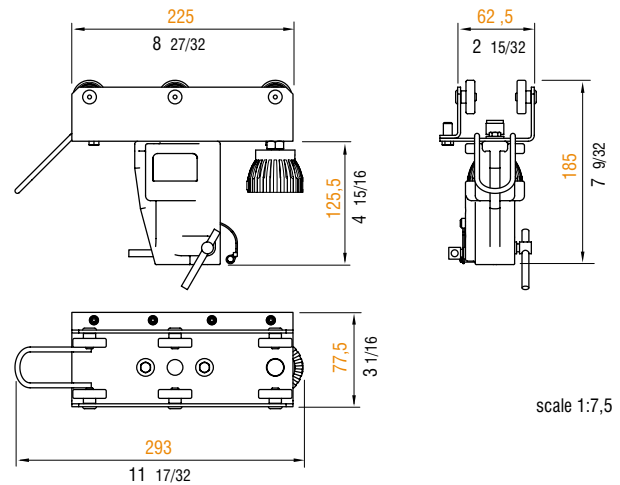

scale 1:7,5

APPLICATIONS

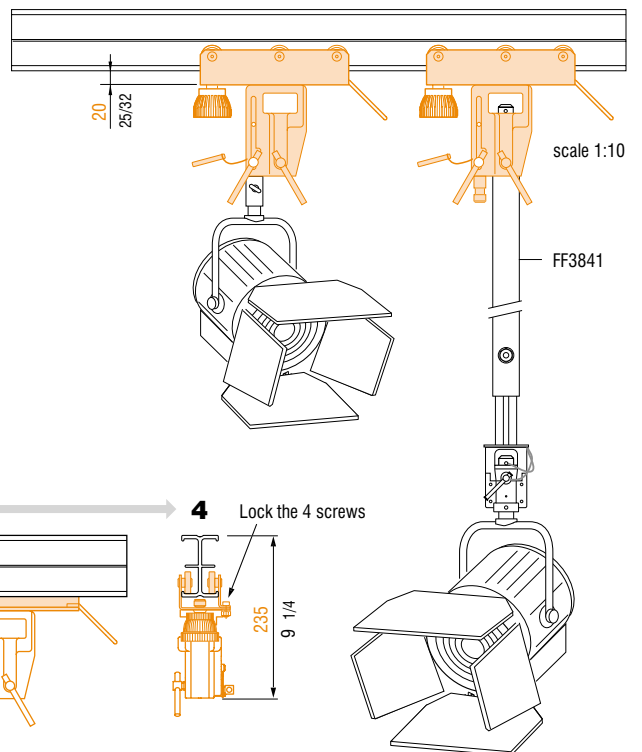
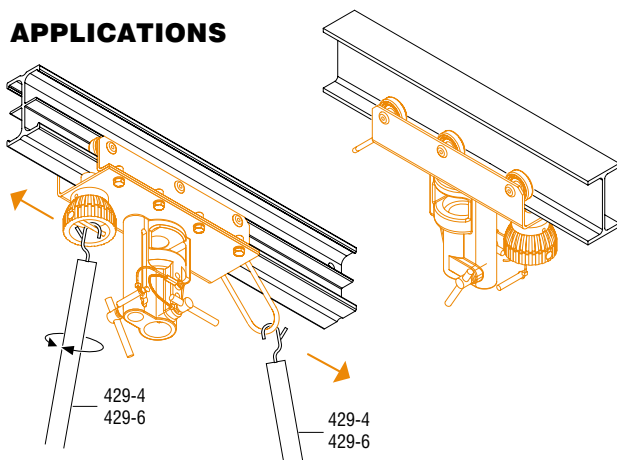

ASSEMBLY SEQUENCE for rail type 80

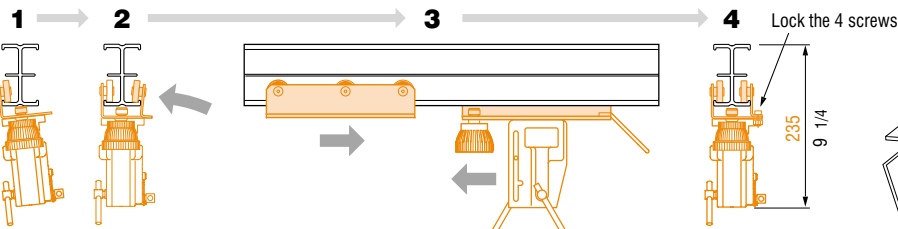

ASSEMBLAGE SEQUENCE for IPE 80 same as art. FF3707S

Metric measurements should be taken as reference. Imperial values have been calculated from metric and rounded to nearest 1/32 inch. IMPORTANT: installation must be carried out by qualified personnel and in accordance with the safety regulations of the country/region of installation.