

C210



Baby pipe clamp with 16 mm stud

Clamping range encompasses pipe from 10 mm to 55 mm diameter.

material: rugged gravity cast aluminium

finish: black powder smooth RAL 9005

weight: 0,62 kg
1,37 lb

volume: 0,006 cu m
0,211 cu ft

max. load: 100 kg
220 lb

weight: 0,7 kg
1,54 lb

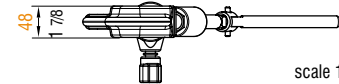
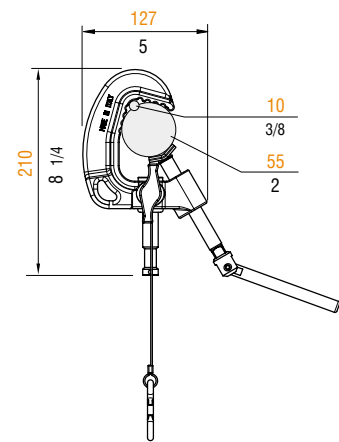
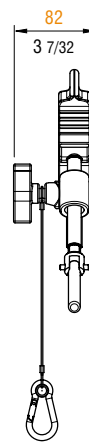

scale 1:7,5

11

APPLICATIONS

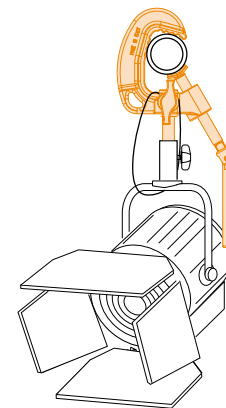
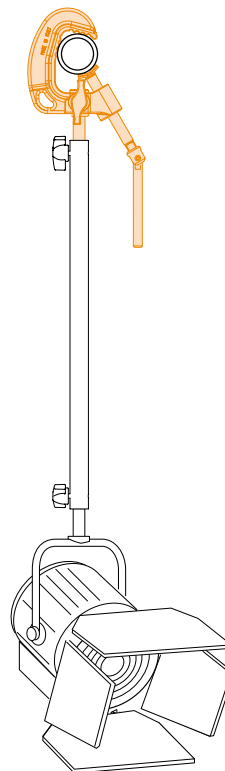
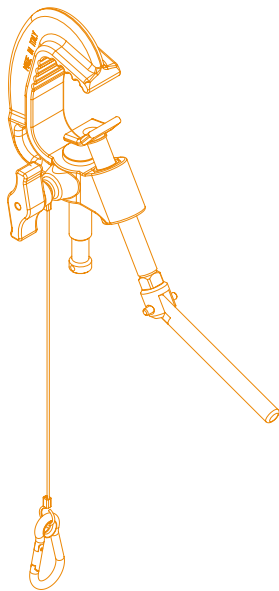

Metric measurements should be taken as reference. Imperial values have been calculated from metric and rounded to nearest 1/32 inch.
IMPORTANT: installation must be carried out by qualified personnel and in accordance with the safety regulations of the country/region of installation.