

FF3710



Detachable carriage with twist lock and 1-1/8" female attachment

One side of the carriage can be removed to attach or detach the carriage to/from the Rail 80. Rail carriage with 1-1/8" female attachment. Twist lock holds carriage in position. Use operating pole to open or release the twist lock.



material main body: steel & aluminium
part: blue plastic



finish: grey powder coating with orange peel finish RAL 7016



weight: 1,684 kg
3,712 lb



volume: 0,0060 cu m
0,2120 cu ft



max. load: 90 kg
198 lb



weight: 1,795 kg
3,954 lb

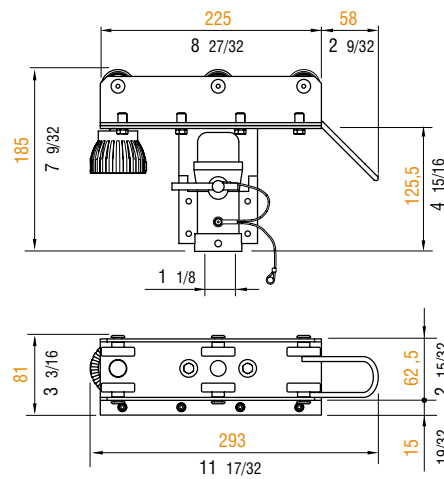

scale 1:7,5

APPLICATIONS

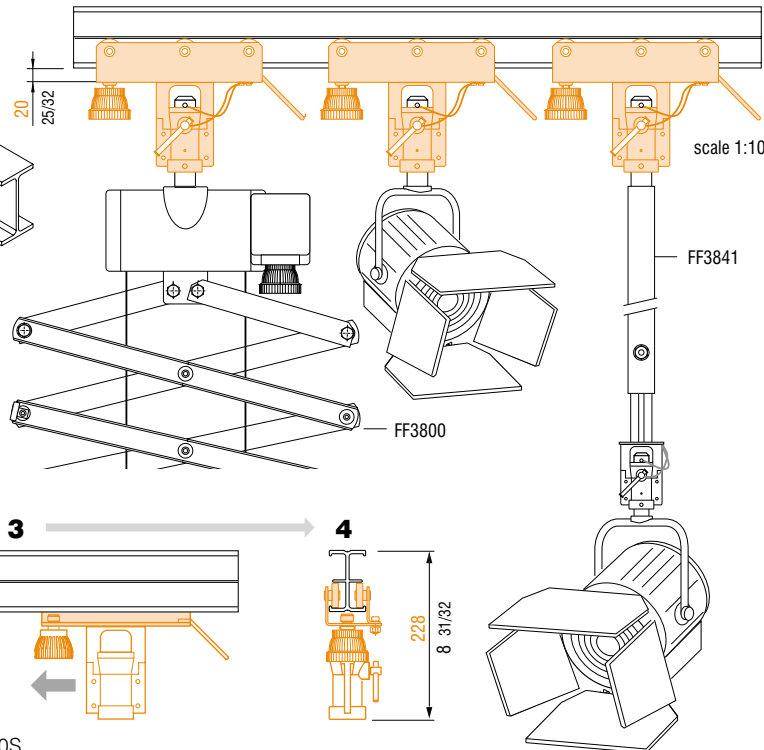
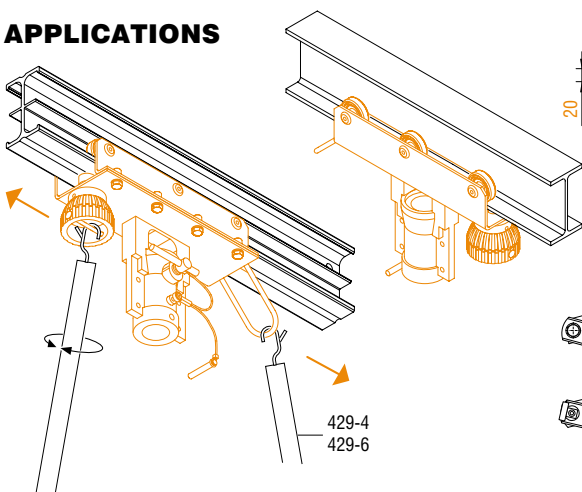

scale 1:10

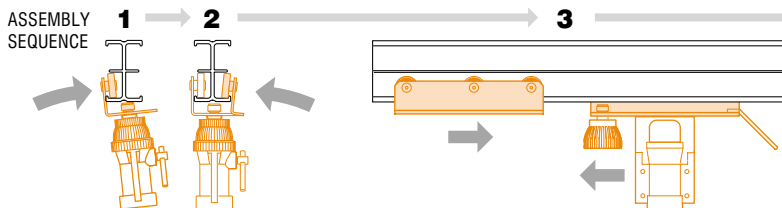

ASSEMBLAGE SEQUENCE for IPE 80 same as art. FF3710S

Metric measurements should be taken as reference. Imperial values have been calculated from metric and rounded to nearest 1/32 inch.
IMPORTANT: installation must be carried out by qualified personnel and in accordance with the safety regulations of the country/region of installation.