

FF3713



Double carriage Rail 80 to Rail 60

Double carriage used to connect moving Rail 60 to a fixed Rail 80; upper carriage with 6 bearing wheels and twist lock lower carriage with 4 bearing wheels and friction brake.



material main body: steel
part: blue plastic



finish: grey powder coating with orange peel finish RAL 7016



weight: 1,700 kg
3,747 lb



volume: 0,0045 cu m
0,1590 cu ft



max. load: 100 kg
220 lb



weight: 1,770 kg
3,902 lb

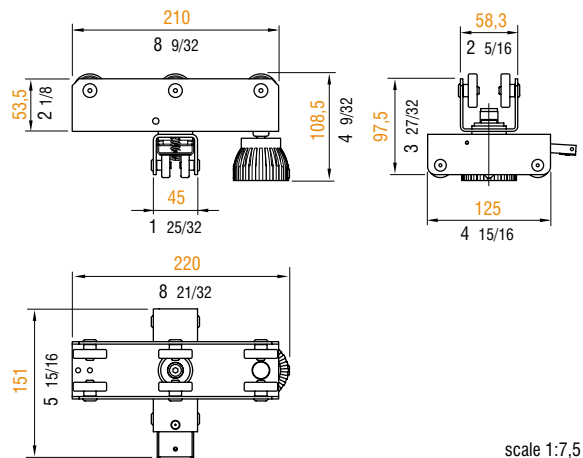

APPLICATIONS

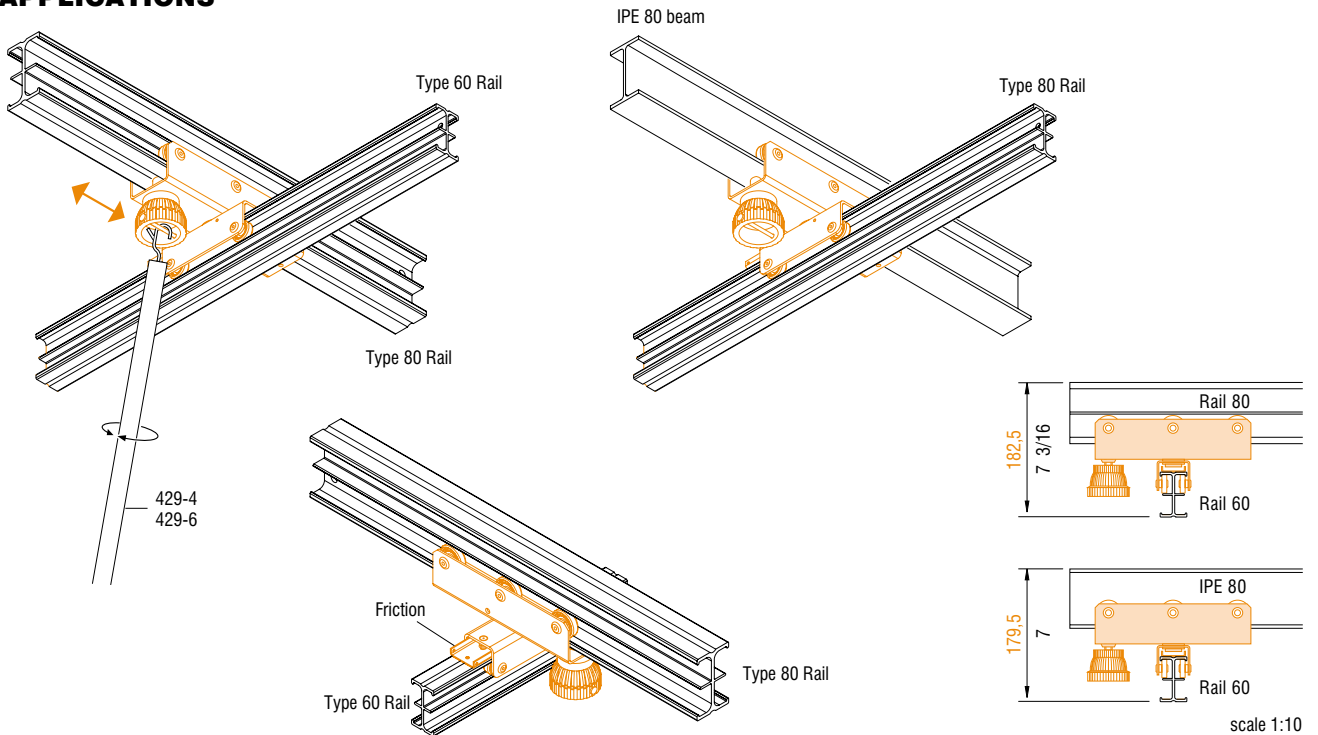

Metric measurements should be taken as reference. Imperial values have been calculated from metric and rounded to nearest 1/32 inch. IMPORTANT: installation must be carried out by qualified personnel and in accordance with the safety regulations of the country/region of installation.