

**FF3700**



Double carriage for Rail 80

Double carriage with 6 bearing wheels each. Upper carriage with twist lock, lower carriage with friction brake.

material main body: steel  
part: blue plastic

finish: grey powder coating with orange peel finish RAL 7016

weight: 1,900 kg  
4,188 lb

volume: 0,0045 cu m  
0,1590 cu ft

max. load: 200 kg  
441 lb

weight: 1,970 kg  
4,343 lb

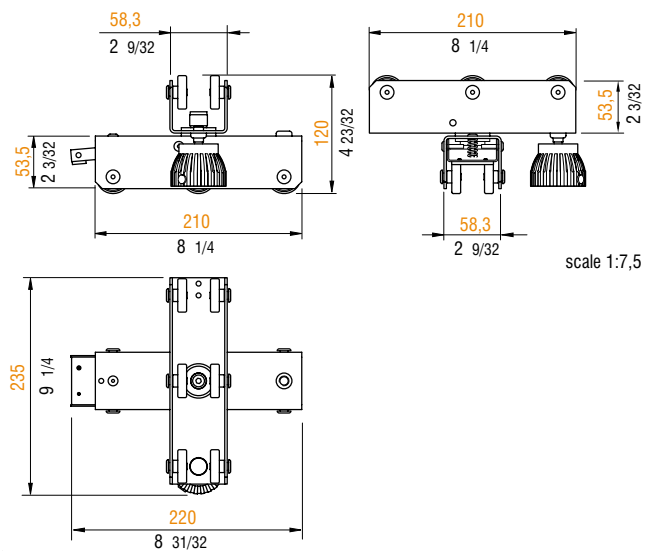

**APPLICATIONS**

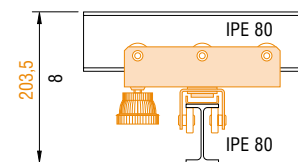
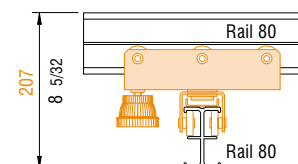
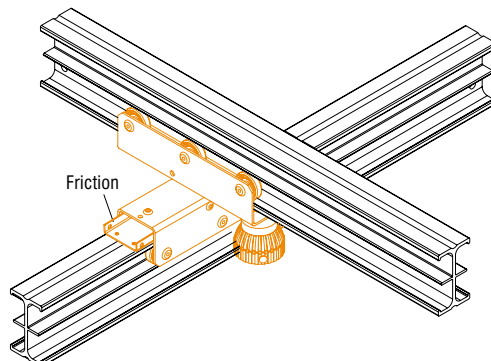
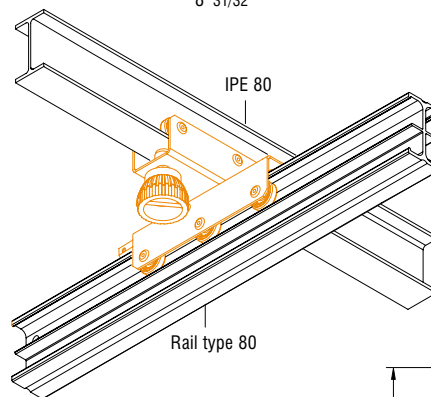
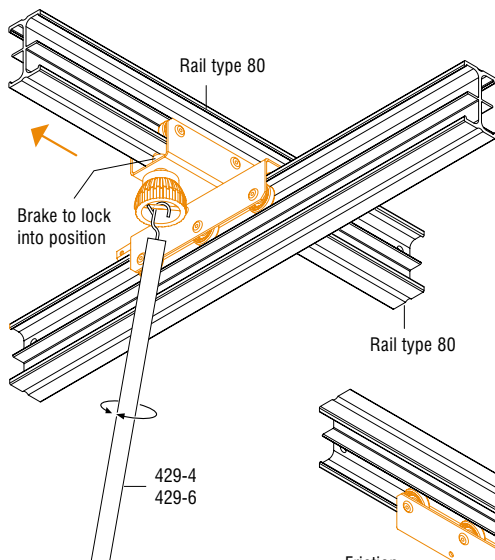

scale 1:10

Metric measurements should be taken as reference. Imperial values have been calculated from metric and rounded to nearest 1/32 inch.   
IMPORTANT: installation must be carried out by qualified personnel and in accordance with the safety regulations of the country/region of installation.